

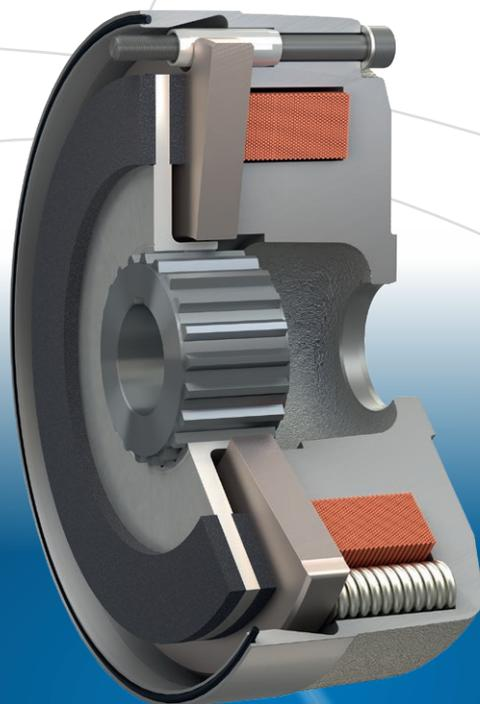

your reliable partner



ROBA-stop[®]-M

Your Reliable Brake

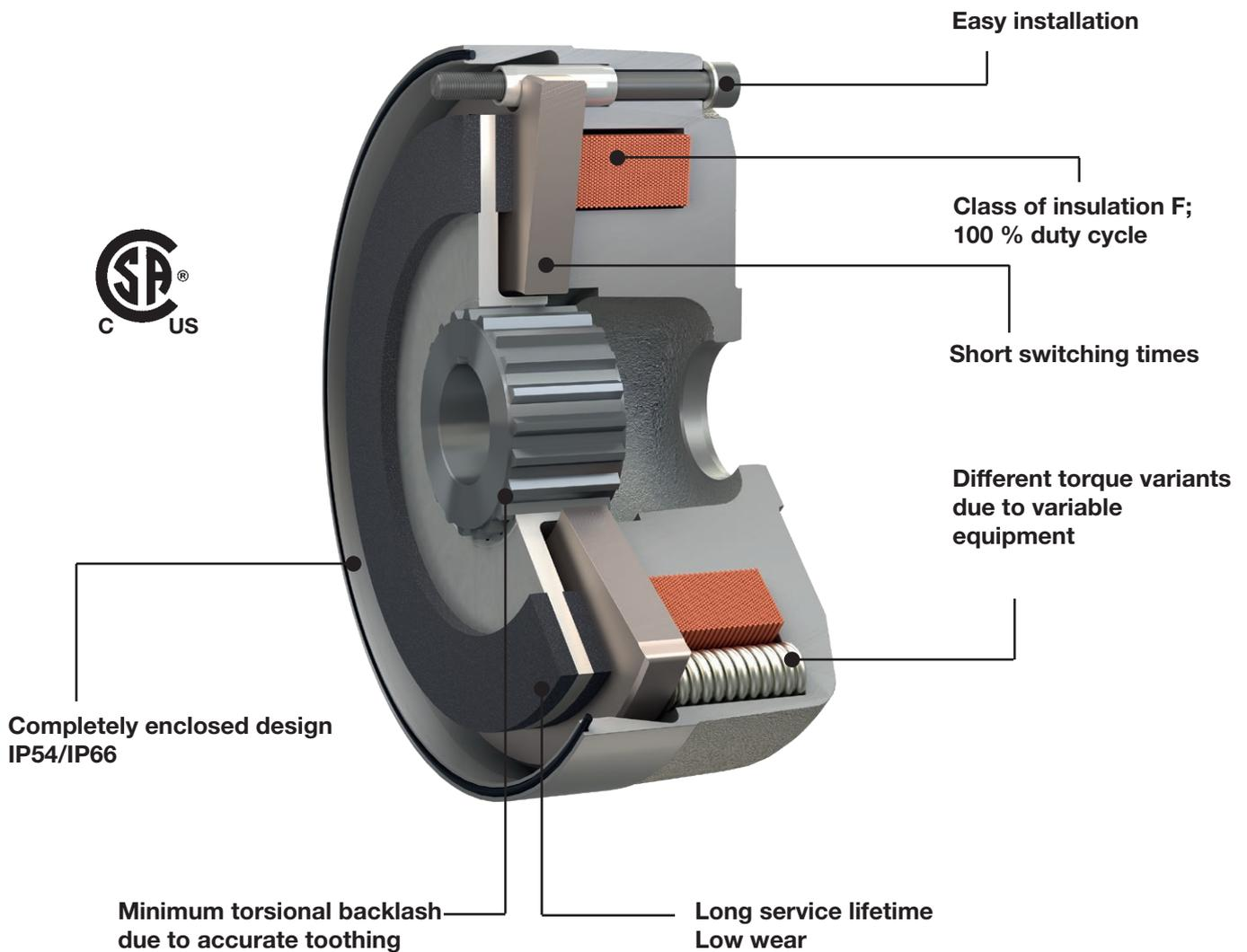

Advantages for Your Applications

- Easy installation
- Brake outer diameter completely enclosed (higher protection can easily be realised)
- Magnetic coil is designed for a relative duty cycle of 100 %
- Magnetic coil and casting compound correspond to class of insulation F
- The nominal air gap is specified by design and inspected
- Short switching times
- Maintenance-free over the entire service lifetime of the rotor



Certain ROBA-stop[®]-M brakes can be used for safety-relevant applications acc. ISO 13849-1 (for Permitted Types, see page 29). For information on the safety parameters, please contact *mayr*[®]power transmission.

Function

ROBA-stop[®]-M brakes are spring applied, electromagnetic safety brakes.

Spring applied function:

In de-energised condition, helical springs (6) press against the armature disk (5). The rotor (3) is held between the armature disk (5) and the corresponding screw-on surface of the machine. The shaft is braked via the toothed hub (1).

Electromagnetic:

When the power is switched on, a magnetic field is built up. The armature disk (5) is attracted to the coil carrier (2) against the spring pressure. The brake is released and the shaft is able to rotate freely.

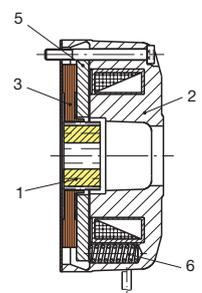

Safety brakes:

The brake brakes reliably and safely in the event of a power switch-off, a power failure or an EMERGENCY STOP.

ROBA-stop®-M

Page 4 ▷

Sizes 2 to 1000

Braking torques

0.7 to 1400 Nm
(Standard brake)

4 to 1800 Nm
(Holding brake)

Permitted shaft diameter

Ø 8 to 90

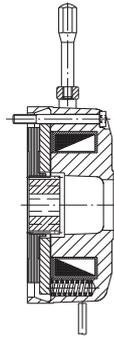

Type 891._.1.0 Standard design

Page 5 ▷

Type 891._.2.0 Standard design with friction disk

Type 891._.4.1 IP66 design with flange plate

Type 891._.4.2 Tacho attachment design with flange plate

Short Description Installation

Page 6 ▷

Brake Dimensioning, Friction-Power Diagrams

Page 8 ▷

Further Options

Page 11 ▷

Switching Times, Electrical Connection, Electrical Accessories

Page 15 ▷

Guidelines on safety-critical applications (acc. ISO 13849-1)

Page 29 ▷

Guidelines

Page 30 ▷

Order Number

Nominal torque holding brake
100% Nominal torque standard

0

1

2

3

4

5

7

8

6

Other braking torque adjustments,
see Table 3, page 7

Nominal torque adjustable ^{2) 6)}

0 Without additional parts

1 Hand release ¹⁾

2 Friction disk ⁷⁾

3 Hand release/Friction disk ^{1) 7)}

4 Flange plate ⁸⁾

5 Hand release/Flange plate ^{1) 8)}

__ / 8 9 1 . __ __ . __ / __ / __ / __

Sizes	Standard brake metal rotor ³⁾	0	Standard ¹¹⁾	0	Coil voltage ⁹⁾	Bore	Keyway acc.
2	Holding brake Metal rotor ^{12) 13)}	1	Enclosed	1	[VDC]	Hub Ø d	DIN 6885/1
to	Standard brake	2	design IP66 ⁵⁾	2	24 ¹⁰⁾	(please observe	or
1000	Friction lining rotor ⁴⁾	5	Tacho design ⁵⁾	3	104	dimensions pages	DIN 6885/3
	Fibre Composite Rotor ^{12) 13)}		Central torque		180	4-5, Table 2,	
			adjustment ²⁾		207	page 7)	

Example: 16 / 891.211.0 / 24 / 16 / 6885/1

For Further Options, see page 11

- 1) Hand release not installed on size 2 – size 500.
size 1000: Hand release only available as emergency hand release.
Hand release for IP66 design only ex works.
- 2) On request
- 3) From size 60
- 4) Up to size 32 (for brake operation in hoisting device drives, please contact the manufacturer)
- 5) Not in combination with friction disk
- 6) Adjustment range is indicated on the configuration drawing

- 7) Sizes 2 – 60
- 8) Standard tacho brake flange plate
- 9) Brake operation only possible with overexcitation
on size 500 from 700 Nm onwards and on size 1000.
- 10) Not possible on size 1000.
- 11) Standard and tacho design are identical on size 1000.
Order number for standard (tacho design) on size 1000:
1000 / 891._.2 / _ / _ / _
- 12) Sizes 2 - 16 only with fibre composite rotor **891.5._. _**
- 13) Applications for hoisting devices and gravity-loaded axes only permitted
with metal rotor or fibre composite rotor



On request ROBA-stop® safety brakes can also be delivered with UL approval.



ROBA-stop®-M safety brakes are also available in ATEX design according to the directive 2014/34/EU. (Please contact *mayr*® power transmission).

ROBA-stop®-M electromagnetic safety brakes

Type 891._.1.0

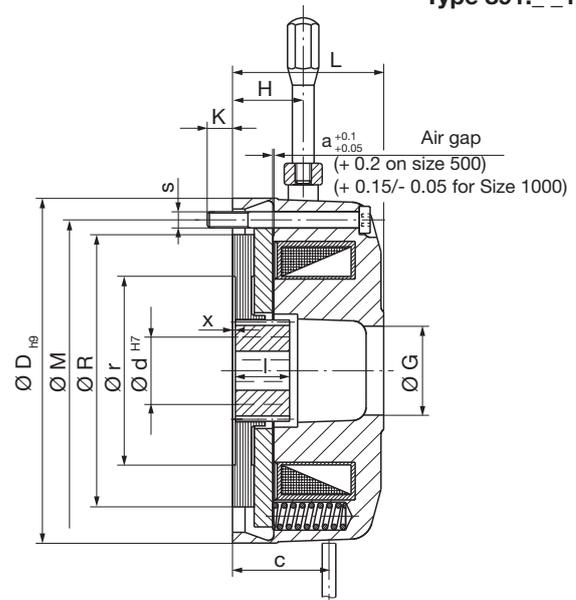
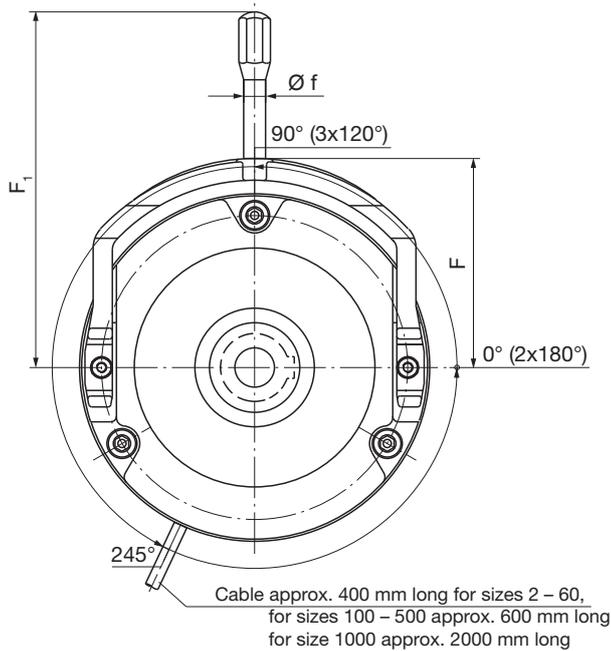

Technical Data				Size											
				2	4	8	16	32	60	100	150	250	500	1000	
Braking torque ^{1.1)}	Standard brake ¹⁾ Type 891.0_._. Type 891.2_._. ⁹⁾	M_N	[Nm]	2	4	8	16	32	60	100	150	250	500	1000	
	Holding brake Type 891.1_._. Type 891.5_._.	M_N	[Nm]	4	8	16	32	64	100	180	280	460	900	1800	
Electrical power		P_N	[W]	19	25	29	38	46	69	88	98	120	152	160	
Maximum speed	Standard brake	n_{max}	[rpm]	6000	5000	4000	3500	3000	3000	3000	4200	3600	3000	2500 ¹⁰⁾	
	Holding brake	n_{max}	[rpm]	6000	5000	4000	3500	3000	3000	3000	3000	2500	2000	1500	
Idle speed	Standard brake		[rpm]	9000	8800	7000	5600	4700	7200	6200	5400	4700	3800	3200	
	Holding brake		[rpm]	9000	8800	7000	5600	7800	7300	6200	5400	4700	3800	3200	
Reference speed		n_{ref}	[rpm]	6000	5000	4000	3000	1500	1500	1500	750	750	750	750	
Weight		m	[kg]	0.76	1.1	1.8	3.4	4.5	7.4	13.6	19.2	33.3	38	79	

Bores				Size											
				2	4	8	16	32	60	100	150	250	500	1000	
Bore $\varnothing d_{H7}^{2)}$	Standard brake Type 891.0_._. Type 891.2_._.	min.	[mm]	8	10	11	14	19	22	24	30	40 ^{1.2)}	50 ^{1.2)}	75	
		max.	[mm]	15	15	20	25	30	35	45	50	60	80	90	
	Please observe Table 2, page 7														
	Holding brake Type 891.1_._. Type 891.5_._.	min.	[mm]	8	10	11	14	19	22	24	30	40	52	75	
max.		[mm]	15	15	20	25	30	35	45	50	55	75	90		
Please observe Table 2, page 7															

Dimensions [mm]	Size											
	2	4	8	16	32	60	100	150	250	500	1000	
a	0.15	0.15	0.2	0.2	0.2	0.25	0.3	0.3	0.35	0.4	0.5	
b	30	30	36	42	52	60	78	84	96	130	180	
b ₁	30	30	36	42	52	62	-	-	-	-	-	
c	24	26.5	28.7	35.5	39.2	50.5	54	59	69	70	85	
c ₁	25	27.5	29.7	36.8	40.5	51.8	-	-	-	-	-	
c ₂	29	32.5	34.7	42.5	47.2	58.5	64	71	83	89	106	
D	76	87	103	128	148	168	200	221	258	310	382	
D ₁	81	92	108	130	148	168	200	221	258	310	382	
D ₂	81	92	108	134	154	174	206	227	266	318	392	
F	48.5	54	63.5	77	88	100.5	123	133	153	179	-	
F ₁	102.5	108	117.5	131	169	228.5	267	347	494	521	-	
f	8	8	8	8	10	14	14	19	23	23	-	

ROBA-stop®-M electromagnetic safety brakes

Type 891._.2.0
Standard with friction disk

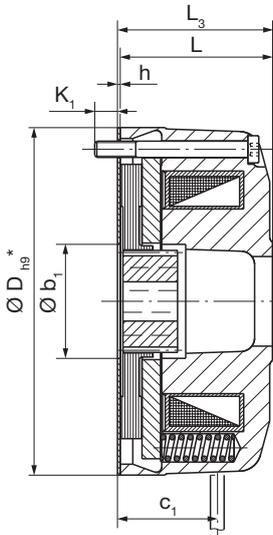

Type 891._.4.1
Enclosed design (IP66)
with flange plate

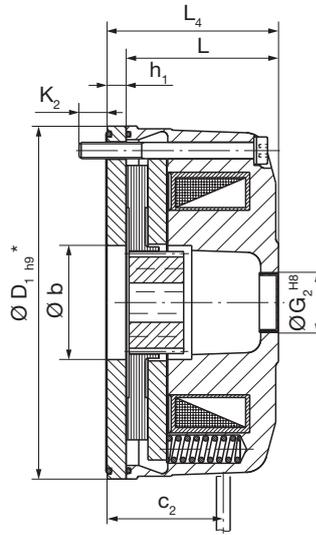

Type 891._.4.2
Tacho attachment design
with flange plate

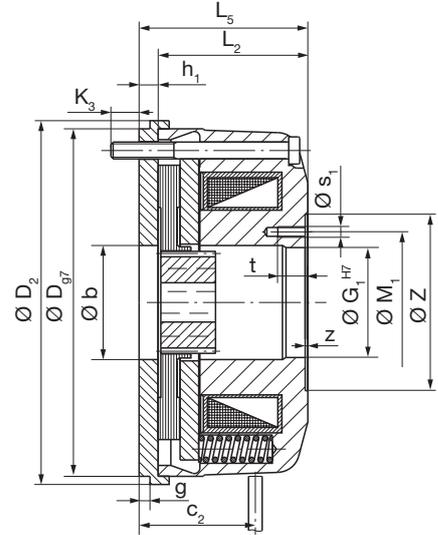

* Outer diameter friction disk: Free size; outer diameter flange plate: -0.2

Missing dimensions are identical with Type 891.011.0 see page 4.

Dimensions [mm]	Size										
	2	4	8	16	32	60	100	150	250	500	1000
G	16.5	18	22	33	36	38	48	55	65	85	100
G ₁	23.5	28.5	32.5	40.5	52.5	60	75.5	82.5	92	131	100
G ₂ ^{H8}	-	-	22	22	28	32	42	48	52	62	100
g	4	4	4	4	4	4	5	6	7	7	7
H	16	14.5	17.5	26	27	26	34	41	46	54.5	-
h	1	1	1	1.25	1.25	1.25	-	-	-	-	-
h ₁	5	6	6	7	8	8	10	12	14	19	21
K	10	10.8	12.5	12.3	8.3	12	12	20	20	22	18.5
K ₁	9	9.8	11.5	11.1	7.1	10.8	-	-	-	-	-
K ₂	10	8.8	11.5	10.3	10.3	14	12	18	25.5	21.5	17.5
K ₃	10	9.8	11.5	10.3	10.3	14	12	18	26	23	19
L	39	41.5	45.2	55.7	61.7	72.5	84	97	116	114	135 ^{5) 6)}
L ₂	38	40.5	44.2	54.7	60.7	71.5	83	96	115	113	135 ⁶⁾
L ₃	40	42.5	46.2	57	63	73.8	-	-	-	-	-
L ₄	44	47.5	51.2	62.7	69.7	80.5	94	109	130	133	170 ⁵⁾
L ₅	43	46.5	50.2	61.7	68.7	79.5	93	108	129	132	156 ⁶⁾
I	18	18	20	20	25	30	30	35	40	50 ³⁾	70
	supporting length of the key										
M	66	72	90	112	132	145	170	196	230	278	325
M ₁	29	35	41	52	61	75	88	100	112	145	115.5
R	57	65	81	101	121	130.5	154	178	206	253	300
R (CCV)	-	-	-	101	121	129.5	154	178	-	-	-
r	45	45	53	70	83	94	106	122	140	161	190
r (CCV)	-	-	-	71	84	94	106	122	-	-	-
s	3 x M4	3 x M4	3 x M5	3 x M6	3 x M6	3 x M8	3 x M8	3 x M8 ⁸⁾	3 x M10 ⁸⁾	6 x M10	6 x M12 ⁷⁾
s ₁	3 x M3	3 x M4	3 x M4	3 x M4	3 x M5	3 x M5	3 x M5	3 x M6	3 x M6	6 x M8	6 x M6
t	6	10	10	10	10	10	10	10	10	13	12
x	0	0	0	0 - 0.5	0 - 0.5	0 - 2	0 - 3	0 - 3	0 - 3	3 - 4	0 - 1.5
Z	36	45	55	65	75	90	100	115	130	175	-
z	1	1	1	1	1	1	1	1	1	1	-

Standard voltages 24; 104; 180; 207 V.

Permitted voltage tolerance acc. DIN IEC 60038 (±10 %).

- 1) Other adjustments, see Table 3, page 7 and type key page 3.
- 1.1) Braking torque tolerance = +40 %/-20 % (friction lining pairing conditioning necessary, see Operational Instructions B.8.1.-).
- 1.2) Minimum bore not permitted for Type 891._.8._.
- 2) The respective maximum bores are to be seen in relation to the corresponding keyways and their tolerances acc. Table 2 page 7.
- 3) Hub facing side (both sides) 3 mm deep, Ø 97 recessed.
- 4) Brake operation only possible with overexcitation

We reserve the right to make dimensional and constructional alterations.

- 5) The IP66 design is equipped with a sealing cover on size 1000: L = 149 mm, L₄ = 170 mm.
- 6) Projection screw plugs (emergency hand release): 8.5 mm
- 7) For flange plate securement: additional 2 x M12 screws
- 8) For flange plate securement: additional 3 x M8/M10 screws
- 9) Only up to Size 32
- 10) Braking torque tolerance für size 1000 over 1800 rpm = +40%/-40%

ROBA-stop®-M – Short Description Installation

Installation Conditions

- ❑ The eccentricity of the shaft end in relation to the mounting pitch circle must not exceed 0.2 mm.
- ❑ The positional tolerance of the threaded holes for the cap screws (Item 8, Fig. 2) must not exceed 0.2 mm.
- ❑ The axial run-out deviation of the screw-on surface to the shaft must not exceed the permitted axial run-out tolerance acc. DIN 42955 N. Larger deviations can lead to a drop in torque, to continuous grinding of the rotor and to overheating.

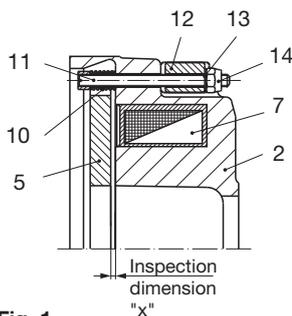

Fig. 1

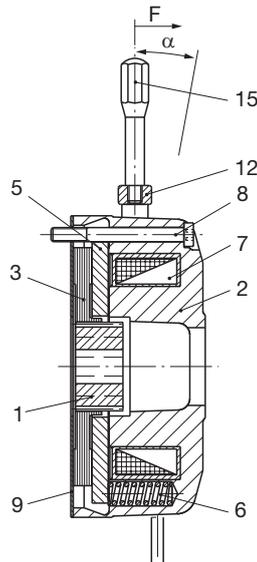

Fig. 2

Installation

1. Mount the hub (1) onto the shaft and secure it axially (e.g. using a locking ring).
 - Recommended tolerance of hub-shaft connection H7/k6.
 - Avoid too tight hub-shaft connections (particularly on max. bores).
 - Keep the friction surfaces free of oil and grease.

Attention!

Please observe supporting length of the key acc. Dimensions on page 5.

2. If necessary (dependent on Type), move the friction disk or the flange plate over the shaft and attach it to the machine wall (or screw on for size 1000).
 - If there are no suitable counter-friction surfaces made of grey cast or steel available, please use brake Types 891._ _2/3._ _ (with friction disk (9)) or 891._ _4/5._ _ (with flange plate).
 - When using a brake with a friction disk (Type 891._ _2/3._ _), please observe the stamp "friction side" on the friction disk.
3. Push the rotor (3) onto the hub (1) by hand.
4. If necessary, install the hand release (only on sizes 2 - 500/the emergency hand release is pre-assembled on size 1000).
5. If necessary (dependent on Type, Type 891._ _1), insert the O-ring into the axial groove of the coil carrier (2).
6. Push the rest of the brake over the hub (1) and the rotor collar (3).
7. Attach the brake onto the motor bearing shield or onto the machine wall evenly all around using the cap screws (8) - please observe the seal dependent on the type - with a torque wrench and tightening torque (acc. Table 1, page 7).

Attention!

Only use mayr® original screws (Table 1, page 7).

Braking Torque Adjustment

Different torque adjustments can be made using different spring configurations (6) in the coil carrier (2) (see Table 3, page 7).

Hand Release Installation (Sizes 2 – 500)

On Type 891._ _1 installation of the hand release is only possible if a request for a hand release is stated on the brake order form (completely enclosed coil carrier (2)).

For hand release installation, the brake must be dismantled and de-energised.

Installation Procedure (Figs. 1 and 2):

1. Unscrew brake from the motor bearing shield or from the machine wall.
2. Remove the sealing plugs from the hand release bores in the coil carrier (2).
3. Put the thrust springs (10) onto the threaded bolts (11). The threaded bolts (11) come manufacturer-side assembled with a key as tension element and secured with adhesive up to Size M60. This connection must not be loosened.
4. Push the threaded bolts (11) with thrust springs (10) from the inside (facing direction on magnetic coil (7)) into the hand release bores in the coil carrier (2).
5. Push the O-rings (only with sealed hand release, Type 891._ _1) over the threaded bolts (11) and insert them into the recesses of the coil carrier (2).
6. Push intermediate plates (only with sealed hand release, Type 891._ _1) over the threaded bolts (11).
7. Mount the switch bracket (12), add the washers (13) and lightly screw on the self-locking hexagon nuts (14).
8. Tighten both hexagon nuts (14) until the armature disk (5) lies evenly against the coil carrier (2).
9. Loosen both hexagon nuts (14) by "Y" turns (see Table 1, page 7), thereby creating an air gap between the armature disk (5) and the coil carrier (2) or the inspection dimension "x" (see Page 7, Table 1).

Attention!

An uneven adjustment dimension on the hand release can cause the brake to malfunction.

10. After installing the release cover, screw the hand release rod (15) into the switch bracket (12) and tighten it. The hand release rod (15) must be secured against loosening using a screw-securing product, e.g. Loctite 243.

Maintenance

ROBA-stop®-M brakes are mainly maintenance-free.

However, the rotor (3) is subject to operational wear.

The friction pairing are robust and wear-resistant. This ensures a particularly long service lifetime of the brake.

If the rotor (3) does become worn due to the high total friction work, and the function of the brake can no longer be guaranteed, the brake can be re-set to its functional state by replacing the rotor. For this, the brake must be cleaned thoroughly.

The wear condition of the rotor (3) is determined by measuring the release voltage (this must not exceed max. 90 % of the nominal voltage on a warm brake), or by measuring the rotor thickness on a dismantled brake ("minimum rotor thickness" acc. Table in the currently valid Installation and Operational Instructions). On sizes 500 and 1000 there is an air gap inspection opening. This means that the brake does not have to be dismantled.

Attention!

The brake function cannot be guaranteed on brakes with a reduced braking torque and/or operation with a fast acting rectifier if the friction linings are heavily worn.

Unpermitted high wear relaxes the thrust springs (6), leading to a drop in torque.

ROBA-stop®-M – Short Description Installation

Technical Data – Installation			Size											
			2	4	8	16	32	60	100	150	250	500	1000	
Inspection dimension	x	[mm]	0.9 ^{+0.1}	0.9 ^{+0.1}	1.1 ^{+0.1}	1.6 ^{+0.1}	1.8 ^{+0.1}	2.2 ^{+0.1}	2.2 ^{+0.1}	2.2 ^{+0.1}	2.4 ^{+0.1}	2.4 ^{+0.1}	-	
Number of rotations	Y	[-]	1.7	1.7	1.5	2.0	2.0	2.0	1.6	1.6	1.5	1.5	-	
Release force	Standard brake Type 891.0_._._ Type 891.2_._._	F	[N]	20	35	70	100	130	220	260	290	350	310	-
	Holding brake Type 891.10_._._ Type 891.5_._._	F	[N]	26	45	90	125	170	300	340	350	430	470	-
Release angle	α	[°]	6	7	7	7	8	10	12	13	10	10	-	
Fixing screws (8) (Item 8, Fig. 2, Page 6)	Type 891._.0_._	[-]	3 x M4 x 45	3 x M4 x 45	3 x M5 x 50	3 x M6 x 60	3 x M6 x 60	3 x M8 x 75	3 x M8 x 80	3 x M8 x 100	3 x M10 x 110	6 x M10 x 110	6 x M12 x 130	
			EN ISO 4762	EN ISO 4762	EN ISO 4762	EN ISO 4762	EN ISO 4762	EN ISO 4762	EN ISO 4762	EN ISO 4762	EN ISO 4762	EN ISO 4762	EN ISO 4762	EN ISO 4762
	Type 891._.4_._	[-]	3 x M4 x 50	3 x M4 x 50	3 x M5 x 55	3 x M6 x 65	3 x M6 x 70	3 x M8 x 85	3 x M8 x 90	3 x M8 x 110	3 x M10 x 130	6 x M10 x 130	6 x M12 x 150	
			EN ISO 4762	EN ISO 4762	EN ISO 4762	EN ISO 4762	EN ISO 4762	EN ISO 4762	EN ISO 4762	EN ISO 4762	EN ISO 4762	EN ISO 4762	EN ISO 4762	EN ISO 4762
Tightening torque	T _A	[Nm]	2.5	2.5	5.0	9.0	9.0	22	22	22	45	45	83	
Rotor thickness “new condition“			[mm]	6.05	6.05	6.9	8	10.4	11.15	14	15.5	17	18.5	18.5

Table 1

Permitted Hub Bores $\varnothing d_{max}$			Size											
			2	4	8	16	32	60	100	150	250	500	1000	
Type 891.0_._._ Type 891.2_._._	Keyway JS9	6885/1	[mm]	13	13	18	22	30	32	42	45	55	75	90
		6885/3	[mm]	15	15	20	25	-	35	45	50	60	80	-
	Keyway P9	6885/1	[mm]	13	13	18	20	28	32	42	45	50	75	90
		6885/3	[mm]	15	15	20	22	30	-	45	50	55	80	-
Type 891.1_._._ Type 891.5_._._	Keyway JS9	6885/1	[mm]	13	13	18	22	30	32	42	45	55	75	90
		6885/3	[mm]	15	15	20	25	-	35	45	50	-	-	-
	Keyway P9	6885/1	[mm]	13	13	18	20	28	32	42	45	50	75	90
		6885/3	[mm]	15	15	20	22	30	-	45	50	55	-	-

Table 2

Braking Torque Adjustments			Size											
			2	4	8	16	32	60	100	150	250	500	1000 ¹⁾	
Holding brake			[Nm]	4	8	16	32	64	100	180	280	460	900 ¹⁾	1800
Standard brake	Braking torque ²⁾	891._.8_._	[Nm]	2.5	5	10	20	40	75	125	210	360	700 ¹⁾	1400
		891._.7_._	[Nm]	2.2	4.5	9	18	36	68	110	180	290	600	1200
		891._.1_._	[Nm]	2	4	8	16	32	60	100	150	250	500	1000
		891._.2_._	[Nm]	1.7	3.4	6.8	13.5	27	50	85	125	215	400	800
		891._.3_._	[Nm]	1.4	2.8	5.5	11	22	41	70	100	180	350	700
		891._.4_._	[Nm]	1	2	4	8	16	30	50	75	125	250	500
891._.5_._	[Nm]	0.7	1.4	2.8	5.5	11	21	-	-	-	200	400		

Table 3

- 1) Brake operation only possible with overexcitation.
- 2) The braking torque (switching torque) is the torque effective in the shaft train of a slipping brake with a sliding speed of 1 m/s in relation to the mean friction radius (acc. VDE 0580/07.2000).

ROBA-stop®-M – Brake Dimensioning

Brake Size Selection

1. Brake selection

$$M_{\text{eff.}} = \frac{9550 \times P}{n} \times K \leq M_2 \quad [\text{Nm}]$$

$$t_v = \frac{J \times n}{9.55 \times M_v} \quad [\text{sec}]$$

$$M_v = M_N + (-) \times M_L \quad [\text{Nm}]$$

2. Inspection of thermic load

$$Q_r = \frac{J \times n^2}{182.4} \times \frac{M_2}{M_v} \quad [\text{J/braking}]$$

Key:

J	[kgm ²]	Mass moment of inertia
K	[-]	Safety factor (≥1.5 –3 x according to conditions)
M _{eff.}	[Nm]	Required braking torque
M _L	[Nm]	Load torque * sign in brackets (-) is valid if load is braked during downward movement
M _N	[Nm]	Nominal torque (Technical Data page 4) <u>Please observe the braking torque tolerance!</u>
n	[rpm]	Speed
P	[kW]	Input power
t _v	[s]	Braking action
t _r	[s]	Connection time (Table 6 page 12)
Q _r	[J]	Friction work present per braking
Q _{r,0.1}	[J]	Friction work per 0.1 mm wear (Table 4)
Q _{r,ges.}	[J]	Friction work up to rotor replacement (Table 4)
Q _{r,zul.}	[J]	Permitted friction work (switching work) per braking action

The permitted friction work (switching work) Q_{r,zul.} per braking for the specified switching frequency can be taken from the Friction-Power Diagrams (page 9).

If the friction work (switching work) per braking is known, the max. switching frequency can also be taken from the friction-power diagrams (page 9).



Due to operating parameters such as sliding speed, pressing or temperature the **wear values** can **only be considered guideline values**.

When using a brake with a friction disk (Type 891._.2._), the max. friction work and friction power must be reduced by 30 % for Sizes 2 – 16 and by 50 % for Sizes 32 – 60. The wear values Q_{r,0.1} and Q_{r,ges.} are therefore not valid.

Friction Work				Size										
				2	4	8	16	32	60	100	150	250	500	1000
per 0.1 mm wear	Standard brake Type 891.0_._. Type 891.2_._.	Q _{r,0.1}	[10 ⁶ J]	35	40	65	100	130	110	140	120	130	170	180
	Holding brake Type 891.1_._. Type 891.5_._.	Q _{r,0.1}	[10 ⁶ J]	7	8	13	20	30	50	60	40	50	70	80
up to rotor replacement	Standard brake Type 891.0_._. Type 891.2_._.	Q _{r,ges.}	[10 ⁶ J]	95	100	162	500	600	590	840	720	780	1700	2000
	Holding brake Type 891.1_._. Type 891.5_._.	Q _{r,ges.}	[10 ⁶ J]	7	8	13	20	45	100	144	160	220	350	480

Table 4

Mass Moment of Inertia Rotor + hub with d _{max}				Size										
				2	4	8	16	32	60	100	150	250	500	1000
Type 891.0_._. (Metal rotor) Type 891.1_._. (Metal rotor)	J _{R+H}	[10 ⁻⁴ kgm ²]		0.12	0.21	0.67	1.74	4.48	6.74	16.54	31.68	61.82	222.6	424
Type 891.2_._. (Friction lining rotor)	J _{R+H}	[10 ⁻⁴ kgm ²]		0.1	0.17	0.58	1.53	4.1	-	-	-	-	-	-
Type 891.5_._. (Fibre Composite Rotor)	J _{R+H}	[10 ⁻⁴ kgm ²]		0.13	0.21	0.60	1.58	-	-	-	-	-	-	-

ROBA-stop®-M – Friction-Power Diagrams

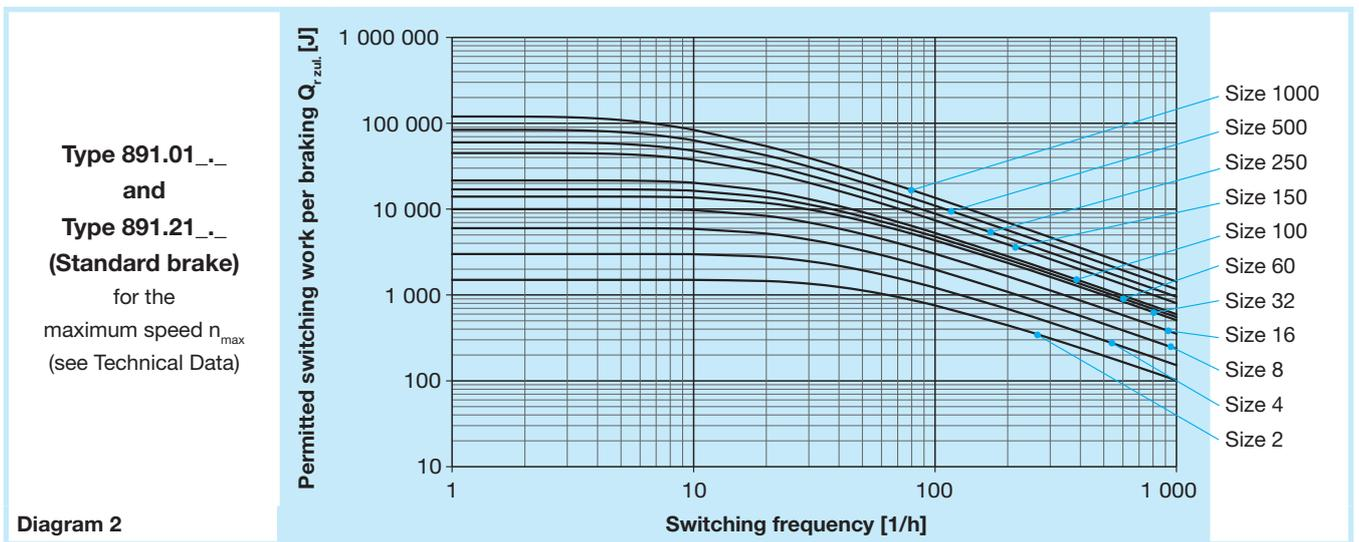
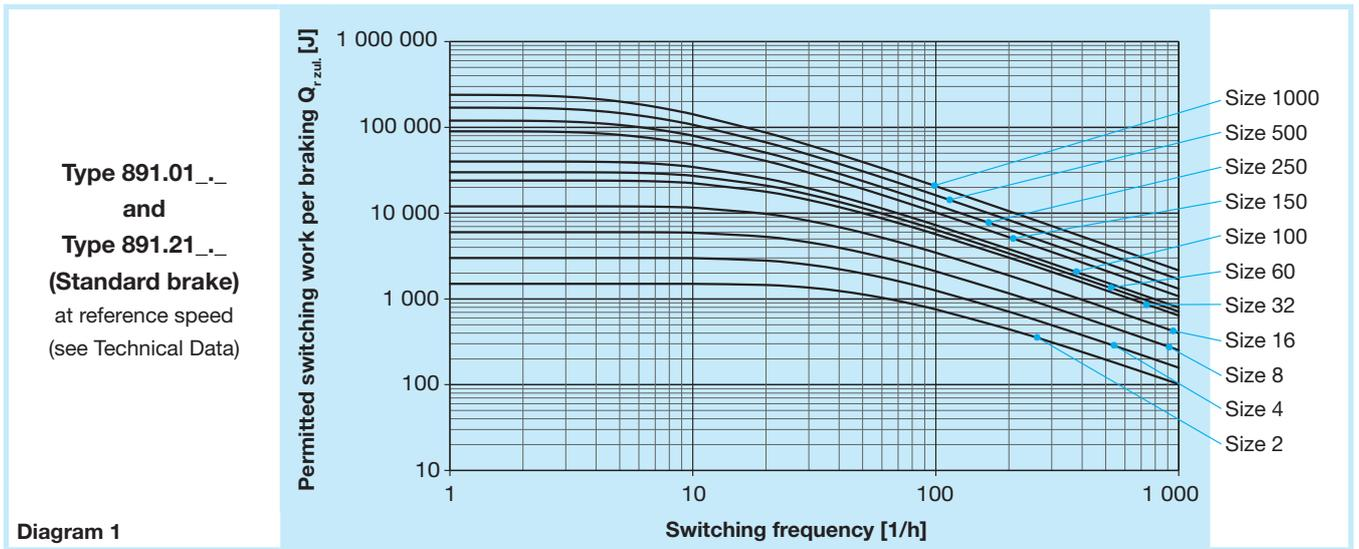

Permitted friction work at other speeds (customer specific)

The permitted friction work at specific customer speeds can also be calculated using linear interpolation between the maximum speed and reference speed.

Data

ROBA-stop®-M

Size		1000
Switching Frequency	1/h	10
Maximum speed	n _{max}	2500 rpm
Customer-specific speed	n	1500 rpm
Reference speed	n _{ref}	750 rpm

Friction power: see friction power diagram

Friction power at reference speed	Q _{n ref}	140000 J
Friction power at maximum speed	Q _{n max}	84000 J

Calculation Example

$$Q_n = Q_{n \text{ ref}} - \frac{(Q_{n \text{ ref}} - Q_{n \text{ max}})}{(n_{\text{max}} - n_{\text{ref}})} \times (n - n_{\text{ref}})$$

$$Q_n = 140000 - \frac{(140000 - 84000)}{(2500 - 750)} \times (1500 - 750)$$

$$Q_n = 116000 \text{ J}$$

ROBA-stop®-M – Friction-Power Diagrams

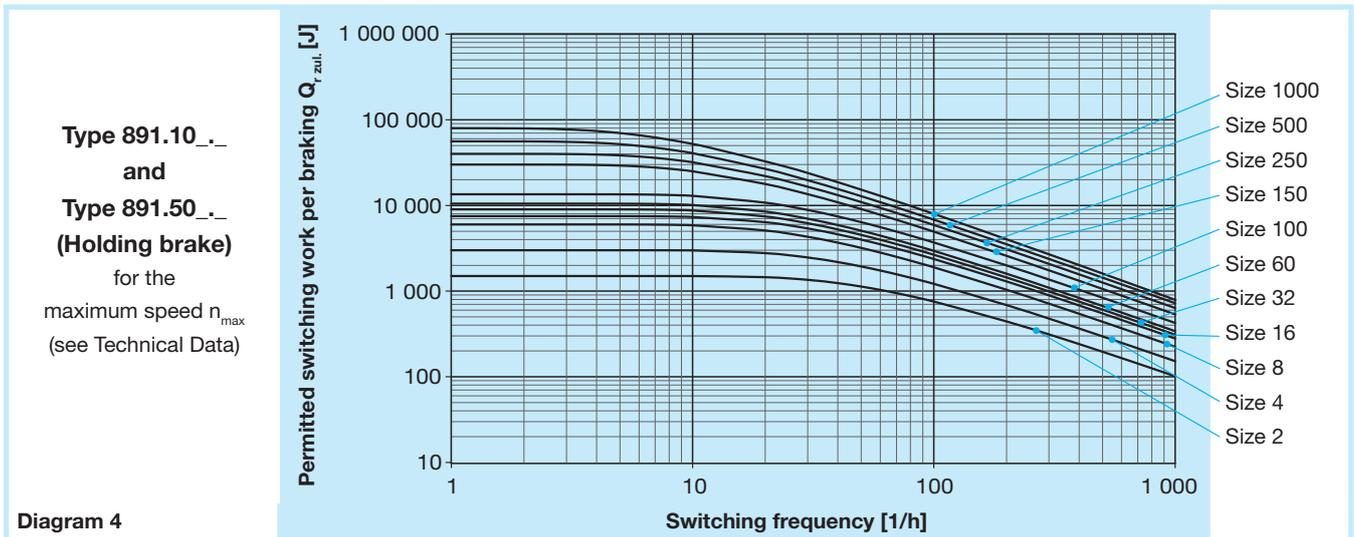
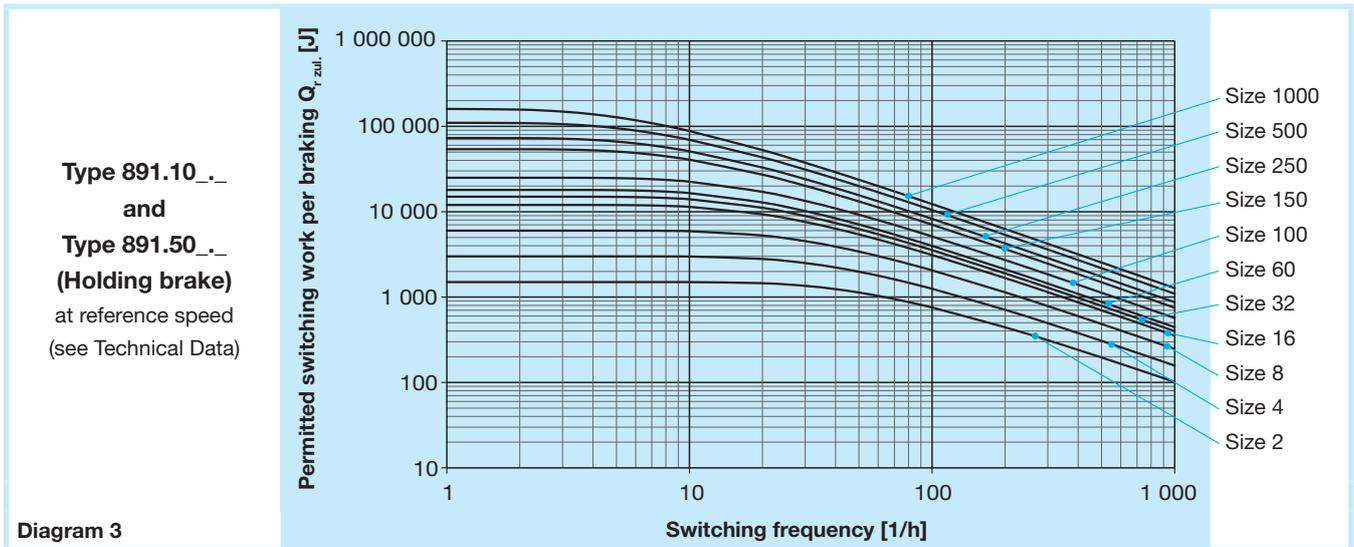

Permitted friction work at other speeds (customer specific)

The permitted friction work at specific customer speeds can also be calculated using linear interpolation between the maximum speed and reference speed.

Data

ROBA-stop®-M

Size		1000
Switching Frequency	1/h	10
Maximum speed	n_{max}	1500 rpm
Customer-specific speed	n	1100 min ⁻¹
Reference speed	n_{ref}	750 rpm

Friction power: see friction power diagram

Friction power at reference speed	$Q_{n,ref}$	88000 J
Friction power at maximum speed	$Q_{n,max}$	50000 J

Calculation Example

$$Q_n = Q_{n,ref} - \frac{(Q_{n,ref} - Q_{n,max})}{(n_{max} - n_{ref})} \times (n - n_{ref})$$

$$Q_n = 88000 - \frac{(88000 - 50000)}{(1500 - 750)} \times (1100 - 750)$$

$$Q_n = 69334 \text{ J}$$

ROBA-stop®-M – Further Options

In addition to the standard brakes, *mayr*® power transmission provides a multitude of further designs, which cannot be described in detail in this catalogue.

Some of the most frequently requested options are:

- Microswitch / proximity switch for switching condition indication (release monitoring), Fig. 1
- Microswitch for wear indication (wear monitoring), Fig. 2
- Customer-specific flange plate, Fig. 3
- IP65 design for continuous shafts, Fig. 4
- Noise damping (O-ring damping between the toothed hub and the rotor), Fig. 5
- ACH = Anti-Condensation heating, Fig. 6
- Lockable hand release, Fig. 7a/7b
- Double rotor design, Fig. 8
- ATEX design
- Special friction material
- Backlash-free design
- Special coil voltages

Please contact *mayr*® power transmission for further information.

Release Monitoring

When the magnetic coil in the coil carrier (2) is energised, the armature disk (3) is pulled towards the coil carrier (2). The microswitch / proximity switch (1) emits a signal and the brake is released.

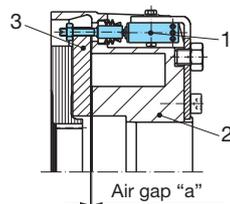

Fig. 1

Continuous shaft with IP65

The enclosed design (IP65) is equipped with a sealing plug (sizes 8 to 500) or with a sealing cover (size 1000) (see Type 891_14.1, page 5) as part of the standard delivery.

A radial shaft sealing ring (1) is installed in the coil carrier (2) on continuous shafts.

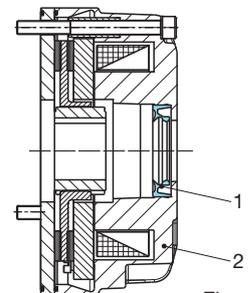

Fig. 4

Wear monitoring

Due to wear on the rotor (5), the nominal air gap "a" between the coil carrier (2) and the armature disk (3) increases. If the limit air gap (see table in the Installation and Operational Instructions) is reached, the microswitch contact (1) switches over and emits a signal. The rotor (5) must be replaced.

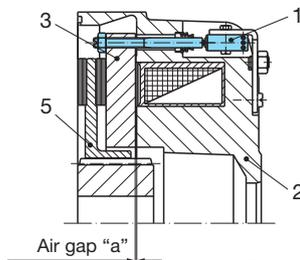

Fig. 2

Damping rotor/toothed hub

If vibrations in the drive line cannot be avoided, an O-ring (1) is used to damp backlash between the toothed hub (6) and the rotor (5).

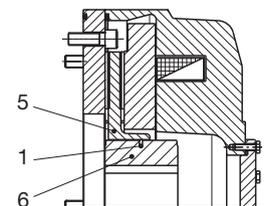

Fig. 5

Special flange plate

We offer a range of flange plates for customer-specific solutions, such as for example the special flange plate shown in fig. 3 (1) with customer-specific centering (8) and sealing (7).

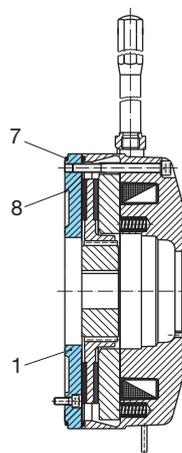

Fig. 3

Anti-condensation heating

The anti-condensation heating (1) is used to prevent condensation formation inside the brake.

Its usage is especially recommended at temperatures below 0 °C or in high air humidity.

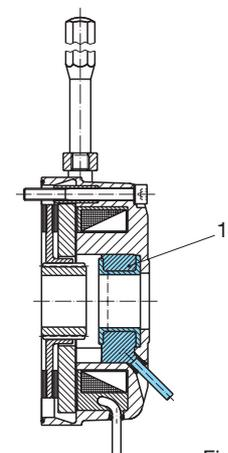
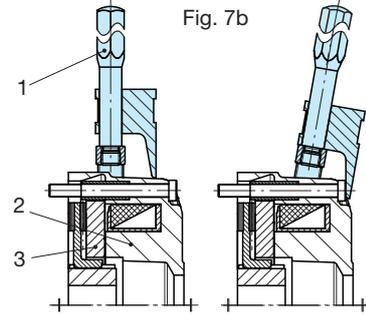
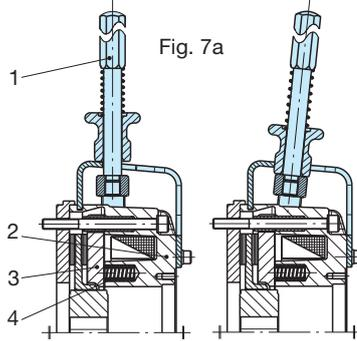

Fig. 6

ROBA-stop®-M – Further Options

Lockable hand release

In de-energised condition, the brake with lockable hand release can be released manually. By deflecting the hand release rod (1), the armature disk (3) is pushed against the coil carrier (2) and the braking torque is removed, Figs. 7a and 7b.



		Hand release in starting position	Hand release in engagement position
Coil	de-energised	Shaft braked	Shaft runs free
	energised	Shaft runs free	Shaft runs free

Double rotor design

Double rotor design for increased braking torque at small outer diameter.

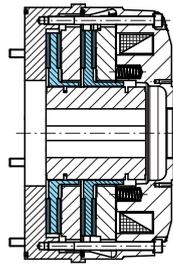
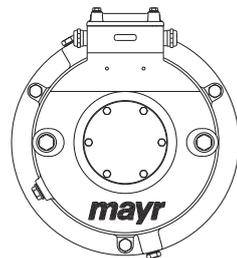

Fig. 8

IP67

For a higher protection IP67 see our product ROBA-stop®-S.



ROBA-stop[®]-M – Further Options

Certified Cold Climate safety brakes for wind power plants (Type 891.4_.._)

The **Cold Climate Version** of our **ROBA-stop[®]-M safety brake** sets new standards for pitch and yaw brakes in low-temperature applications. It is the **only electromagnetic safety brake certified by Germanischer Lloyd (GL)** for applications to -40 °C.

These certified **pitch and yaw safety brakes** work reliably even in the most arduous climatic conditions and ensure the operation of your systems – even at temperatures of minus 40 °C.

Checked
up to -40 °C



ROBA-stop[®]-M – Further Options

Certified Cold Climate safety brakes for wind power plants (Type 891.4_ _.)

Technical Data					Size				
					16	32	60	100	150
Nominal braking torque	Standard	Type 891.41_ _.	M _{nenn}	[Nm]	20	40	75	130	200
		Braking torque adjustment	Reduced	Type 891.42_ _.	[Nm]	17	34	63	110
Type 891.43_ _.	[Nm]			14	27	51	90	130	
Type 891.44_ _.	[Nm]			10	20	38	65	100	
Type 891.45_ _.	[Nm]			7	13.5	26	45	65	
Increased	Type 891.47_ _.		[Nm]	23	46	86	145	-	
		Type 891.48_ _.	[Nm]	26	50	100	160	-	
Electrical power			P _{nenn}	[W]	38	46	69	88	98
Maximum speed			n _{max}	[rpm]	3500	3000	3000	2500	1500
Weight		Standard brake Type 891.41_ _.	m	[kg]	3.4	4.5	7.4	13.6	19.2

Permitted hub bore					Size					
					16	32	60	100	150	
Ø d ^{H7}	Type 891.41_ _. to Type 891.45_ _.	Keyway JS9	6885/1	min.	[mm]	14	19	22	29	38
				max.		23	28.5	31	41.5	44
		6885/3	min.	17.5	21.5	26	-	-		
			max.	24	30	33	-	-		
	Type 891.47_ _. Type 891.48_ _.	Keyway JS9	6885/1	min.	[mm]	14.5	19	23	35.5	-
				max.		21.5	27	29	39	-
		6885/3	min.	17.5	22.5	30.5	-	-		
			max.	22.5	29.5	-	-	-		

We reserve the right to make dimensional and constructional alterations.

Order Number

Braking torque Standard	1	0	Without additional parts
Braking torque adjustment Reduced ¹⁾	2	4	Flange plate
Braking torque adjustment Reduced ¹⁾	3		
Braking torque adjustment Reduced ¹⁾	4		
Braking torque adjustment Reduced ¹⁾	5		
Braking torque adjustment Increased ¹⁾	7		
Braking torque adjustment Increased ¹⁾	8		

Size	Cold Climate safety brake CCV	Standard Enclosed design IP66 Tacho design	Coil voltage [VDC]	Hub bore Ø d ^{H7}	Keyway acc. DIN 6885/1 or DIN 6885/3
16 to 150	4	0 1 2	24 104 180 207		

Example: 16 / 891.430.0 / 24 / 16 / 6885/1

1) See Technical Data.

ROBA-stop®-M – Switching Times

Switching Times

The values stated in the table are mean values which refer to the nominal air gap and the nominal torque on a warm brake.

Switching times ¹⁾			Size										
			2	4	8	16	32	60	100	150	250	500	1000
Nominal torque Type 891._1._.	M_2	[Nm]	2	4	8	16	32	60	100	150	250	500	1000
Connection time	DC-side switching	t_1	[ms]	10	18	20	30	50	55	68	80	100	180
	AC-side switching	t_1	[ms]	100	160	220	320	400	500	640	730	1100	1200
Response delay on connection	DC-side switching	t_{11}	[ms]	6	12	16	25	35	35	38	40	50	70
	AC-side switching	t_{11}	[ms]	80	130	175	240	300	350	400	450	700	750
Separation time ²⁾	t_2	[ms]	33	36	54	84	120	180	216	264	348	480	336 ³⁾
Nominal torque Type 891._2._.	M_2	[Nm]	1.7	3.4	6.8	13.5	27	51	85	125	215	400	840
Connection time	DC-side switching	t_1	[ms]	16	29	32	48	80	88	109	128	160	288
	AC-side switching	t_1	[ms]	160	256	352	512	640	800	1024	1168	1760	1920
Response delay on connection	DC-side switching	t_{11}	[ms]	9.6	19	26	40	56	56	61	64	80	112
	AC-side switching	t_{11}	[ms]	128	208	280	384	480	560	640	720	1120	1200
Separation time	t_2	[ms]	24	26	39	61	87	130	157	191	252	348	235 ³⁾
Nominal torque Type 891._3._.	M_2	[Nm]	1.4	2.8	5.5	11	22	42	70	100	180	350	680
Connection time	DC-side switching	t_1	[ms]	22	40	44	66	110	121	150	176	220	396
	AC-side switching	t_1	[ms]	220	352	484	704	880	1100	1408	1606	2420	2640
Response delay on connection	DC-side switching	t_{11}	[ms]	13	26	35	55	77	77	84	88	110	154
	AC-side switching	t_{11}	[ms]	176	286	385	528	660	770	880	990	1540	1650
Separation time	t_2	[ms]	21	23	34	53	75	113	135	165	218	300	203 ³⁾

Table 6

- Standard brakes with braking torque adjustment Type 891._4._. and Type 891._5._. have significantly longer connection times t_1 and must not be used for switching-time relevant applications.
- The separation time t_2 of holding brakes is 1.4 times longer than the separation time of standard brakes (Type 891._1._.).
- Value for operation with overexcitation

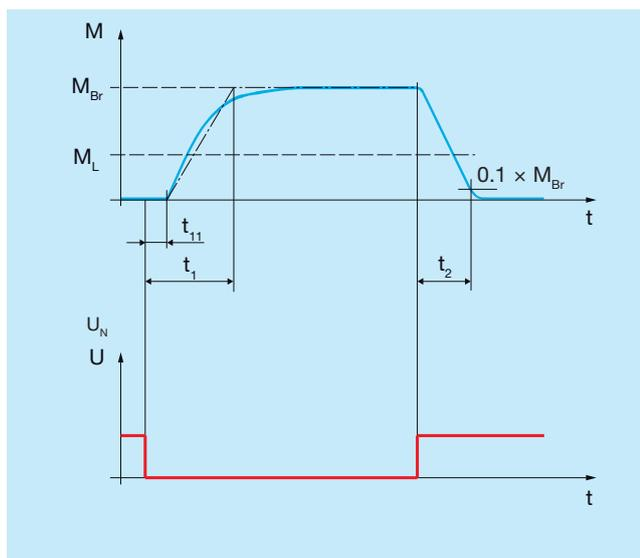

Diagram 5: Switching times for brake operation with coil nominal voltage

Key:

- M_{Br} = Braking torque
- M_L = Load torque
- t_1 = Connection time
- t_{11} = Response delay on connection
- t_2 = Separation time
- U_N = Coil nominal voltage



For brake operation with ROBA®-brake-checker plus AC the switching times t_2 may differ. Please contact *mayr*® power transmission.

ROBA-stop®-M – Electrical Connection

Electrical Connection and Wiring

DC current is necessary for operation of the brake. The coil voltage is indicated on the Type tag as well as on the brake body and is designed according to the DIN IEC 60038 ($\pm 10\%$ tolerance). Operation can take place with alternating voltage using a *mayr*®-DC voltage module or another suitable DC power supply. The connection possibilities can vary dependent on the brake equipment. Please follow the exact connections according to the Wiring Diagram. The manufacturer and the user must observe the applicable regulations and standards (e.g. DIN EN 60204-1 and DIN VDE 0580). Their observance must be guaranteed and double-checked!

Grounding Connection

The brake is designed for Protection Class I. This protection covers not only the basic insulation, but also the connection of all conductive parts to the protective conductor (PE) on the fixed installation. If the basic insulation fails, no contact voltage will remain. Please carry out a standardised inspection of the protective conductor connections to all contactable metal parts!

Device Fuses

To protect against damage from short circuits, please add suitable device fuses to the mains cable.

Switching Behavior

The reliable operational behavior of a brake is to a large extent dependent on the switching mode used. Furthermore, the switching times are influenced by the braking torque adjustment, temperature and the air gap between the armature disk and the coil carrier (dependent on the wear condition of the linings).

Magnetic Field Build-up

When the voltage is switched on, a magnetic field is built up in the brake coil, which attracts the armature disk to the coil carrier and releases the brake.

• Field Build-up with Normal Excitation

If the magnetic coil is energized with nominal voltage, the coil current does not immediately reach its nominal value. The coil inductivity causes the current to increase slowly as an exponential function. Accordingly, the build-up of the magnetic field takes place more slowly and the braking torque drop (curve 1, diagram 6) is also delayed.

• Field Build-up with Overexcitation

A quicker drop in braking torque is achieved if the coil is temporarily placed under a higher voltage than the nominal voltage, as the current then increases more quickly.

Once the brake is released, it needs to be switched over to the nominal voltage (curve 2, diagram 6). The relationship between overexcitation and separation time t_2 is roughly indirectly proportional. This means that, using overexcitation voltage U_o (= doubled nominal voltage U_N), the separation time t_2 for release of the brake is halved. The ROBA®-switch fast acting rectifier works on this principle.

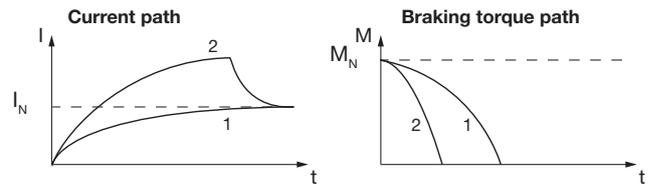

Diagram 6

Operation with overexcitation requires an inspection of:

- the required overexcitation time *
- as well as the RMS coil capacity ** with a cycle frequency higher than 1 cycle per minute (see page 14).

* Overexcitation time t_o

Increased wear, and therefore an increasing air gap as well as coil heating lengthen the separation times t_2 for the brake. For this reason, at least double the separation time t_2 at nominal voltage must be selected as overexcitation time t_o on each brake size

The spring forces also influence the brake separation times t_2 : Higher spring forces increase the separation times t_2 and lower spring forces reduce the separation times t_2 .

**** Coil capacity P**



$$P \leq P_N$$

The coil capacity P must not be larger than P_N . Otherwise the coil may fail due to thermal overload.

Calculations:

P [W] RMS coil capacity dependent on switching frequency, overexcitation, reduction in capacity and duty cycle

$$P = \frac{P_O \times t_o + P_H \times t_H}{T}$$

P_N [W] Coil nominal capacity (catalogue values, Type tag)

P_O [W] Coil capacity on overexcitation

$$P_O = \left(\frac{U_O}{U_N} \right)^2 \times P_N$$

P_H [W] Coil capacity at reduced capacity

$$P_H = \left(\frac{U_H}{U_N} \right)^2 \times P_N$$

t_o [s] Overexcitation time

t_H [s] Time of operation with reduction in capacity

t_{off} [s] Time without voltage

t_{on} [s] Time of operation ($t_o + t_H$)

T [s] Total time ($t_o + t_H + t_{off}$)

U_O [V] Overexcitation voltage (bridge voltage)

U_H [V] Holding voltage (half-wave voltage)

U_N [V] Coil nominal voltage

Time Diagram:

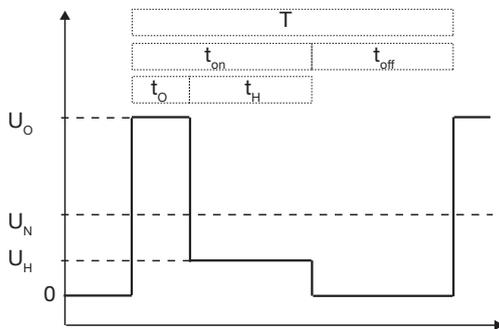
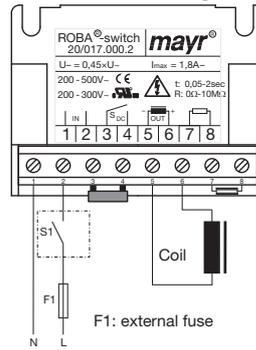

Diagram 7

For brakes, which do not require overexcitation, the holding voltage U_H may be lower than the nominal voltage U_N , e.g. on power reduction to reduce the coil temperature.

Magnetic Field Removal

• AC-side switching



The power circuit is interrupted in front of the *mayr*-DC voltage module. The magnetic field slowly reduces. This delays the rise in braking torque.

When switching times are not important, please switch AC-side, as no protective measures are necessary for the coil and the switching contacts.

AC-side switching means **low-noise switching**; however, the brake engagement time is longer (approx. 6 – 10 times longer than with DC-side switch-off), use for non-critical braking times.

• DC-side switching

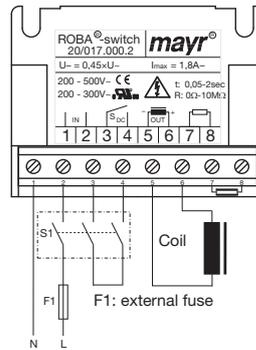

The power circuit is interrupted between the *mayr*-DC voltage module and the coil as well as mains-side. The magnetic field reduces extremely quickly. This causes a quick rise in braking torque.

When switching DC-side, high voltage peaks are produced in the coil, which can lead to wear on the switching contacts from sparks and to destruction of the insulation.

DC-side switching means **short brake engagement times (e.g. for EMERGENCY STOP operation)**; however, louder switching noises.

• Protection Circuit

When using DC-side switching, the coil must be protected by a suitable protection circuit according to VDE 0580, which is integrated in *mayr*-DC voltage module. To protect the switching contact from consumption when using DC-side switching, additional protective measures may be necessary (e.g. series connection of switching contacts). The switching contacts used should have a minimum contact opening of 3 mm and should be suitable for inductive load switching. Please make sure on selection that the rated voltage and the rated operating current are sufficient. Depending on the application, the switching contact can also be protected by other protection circuits (e.g. *mayr*-spark quenching unit), although this may of course then alter the switching times.

Supplying – Protecting – Monitoring – Checking

Electronic mayr® – DC Voltage Modules for Safety brakes

All technical data of the DC voltage modules can be found on our Homepage

Function	Supplying						Protecting
Module	Type 024.000.6 Half-wave rectifier	Type 025.000.6 Bridge rectifier	Type 017_00.2 ROBA®-switch	Type 017.110.2 ROBA®-switch	Type 018.100.2 ROBA®-switch 24V	Type 019_00.2 ROBA®-multiswitch	Type 070.000.6 Spark quenching unit
Overexcitation / Power reduction			X	X	X	X	
DC-side disconnection				X	X		
Mains/input voltage	up to 600 VAC	up to 230 VAC	100 to 500 VAC	100 to 500 VAC	24 VDC	100 to 275 VAC 200 to 500 VAC	Max. 300 VDC
Output voltage/ Overexcitation voltage	up to 270 VDC dependent on the mains voltage VDC = 0.45 x VAC	up to 207 VDC dependent on the mains voltage VDC = 0.9 x VAC	90 to 450 VDC dependent on the mains voltage VDC = 0.9 x VAC	90 to 450 VDC dependent on the mains voltage VDC = 0.9 x VAC	24 VDC	90 VDC (Size 10) 180 VDC (Size 20) constant / independent of the mains voltage	
Nominal voltages			45 to 225 VDC dependent on the mains voltage VDC = 0.45 x VAC	45 to 225 VDC dependent on the mains voltage VDC = 0.45 x VAC	6 VDC 8 VDC 12 VDC 16 VDC	52 VDC (Size 10) 104 VDC (Size 20) constant / independent of the mains voltage	
Switching times			0.05 to 2 s	0.05 to 2 s	0.15 s / 0.45 s / 1 s, 1.5 s / 2.15 s	0.15 s / 0.45 s / 1 s, 1.5 s / 2 s	
Output current	4.0 A	2.5 A	3.0 A (at 250 VAC)	1.5 A	5.0 A	2.0 A (Size 10) 4.5 A (Size 20)	
Characteristics / Application	Standard application Compact construction	Standard application, preferred for noise-damped brakes Compact construction	Short separation time	Short separation time and short connection time	Short separation time and short connection time no wear on contacts	Short separation time Consistently controlled output voltage with variable input voltage	Reduces switch-off voltage and wear on contacts

Monitoring		Monitoring and Supplying			Checking / Controlling and Monitoring	Safe control and monitoring
Type 058.600.2 ROBA®-brake-checker DC	Type 059.500.2 ROBA®-brake-checker AC	Type 028.100.2 ROBA®-brake-checker plus DC	Type 028.600.2 ROBA®-brake-checker plus DC	Type 029.700.2 ROBA®-brake-checker plus AC	Type 068.200.2 ROBA®-torqcontrol DC	Type 021.100.2 ROBA®-SBCplus
		X	X	X	X	X
		X	X		X	X
Max. 50 VDC	Max. 207 VDC ¹⁾ Max. 432 VDC ¹⁾	24 VDC (Size 2) 48 VDC (Size 4)	24 VDC	200 to 480 VAC	24 VDC or 48 VDC	24 VDC or 48 VDC
dependent on the supply	dependet on supply ¹⁾	24 VDC (Size 2) 48 VDC (Size 4)	24 VDC	104 / 52 VDC 207 / 104 VDC 185 / 104 VDC 360 / 185 VDC	24 VDC or 48 VDC	24 VDC or 48 VDC
dependent on the supply	dependet on supply ¹⁾	4 / 6 / 8 / 12 / 16 VDC (Size 2) 8 / 12 / 16 / 24 / 32 VDC (Size 4) constant / independent of the supply voltage	4 / 12 / 16 VDC further voltages available on request	52 VDC 104 VDC 185 VDC	4/6/8/12/16 VDC (24 VDC) 8/12/16/24/32 VDC (48 VDC) constant / independent of the supply voltage	6 VDC 8 VDC 12 VDC 16 VDC 24 VDC 32 VDC
		adapted to brake specifications	adapted to brake specifications	adapted to brake specifications	adapted to brake specifications	0.1 s to 2.5 s
10 A	3.5 A	10.0 A (Size 2) 5.0 A (Size 4)	5.0 A	2.0 A	10.0 A (24 VDC) 5.0 A (48 VDC)	24 VDC/2x5.5 A 48 VDC/2x2.75 A
integrated release and drop-out recognition Brake status display preventative function monitoring	integrated release and drop-out recognition Brake status display preventative function monitoring ¹⁾ Supply with half-wave rectifier, bridge rectifier oqqr ROBA®-switch not via ROBA®-multiswitch	integrated release and drop-out recognition Brake status display short separation time and short connection time no wear on contacts preventative function monitoring	integrated release and drop-out recognition Brake status display short separation time and short connection time no wear on contacts preventative function monitoring	integrated release and drop-out recognition Brake status display short separation time and short connection time preventative function monitoring	Setting of spring force and braking torque Integrated release and drop-out recognition Brake status display Short separation time and short connection time No wear on contacts	Controlling and monitoring up to two ROBA-stop® safety brakes , particularly in applications with requirements on personal protection according to standards on Functional Safety such as for example ISO 13849 and IEC 62061

Additional Information



The catalogue contains basic information on pre-selection and dimensioning.

For detailed information on selection, brake dimensioning, electrical connection, installation and initial operation, please see the Installation and Operational Instructions B.8.1.

If you have any questions regarding the selection and dimensioning, please contact our headquarters.

Safety-relevant Applications

Brakes which are used in safety-related applications are to be selected in accordance with the risk assessment EN ISO 12100 and furthermore in accordance with EN ISO 13849-1 through identification of the safety function.

This is in principle the task of the system manufacturer.

Roba-stop[®]-M standard designs with safety parameters:

- Type 891.10_._ Nominal torque holding brake
- Type 891.50_._ Nominal torque holding brake
- Type 891.01_._ Nominal torque standard
- Type 891.02_._
- Type 891.03_._
- Type 891.07_._
- Type 891.08_._

Customer-specific designs on request.

Safety parameters can be requested if required.

In case of deviating designs, please consult with *mayr*[®] power transmission directly.

Secure Control acc. EN ISO 13849-1

For safe control, a brake control module specially developed for such applications, is available. According to SIL 3 Level, two brake circuits can be supplied.

For detailed information please see page 27.

Additional Supply and Control Modules

For controlling the **ROBA-stop[®]-M**, additional suitable supply and control modules are available.

For overview and functions, please see page 18/19.

Available quickly as PDF download

We would be happy to mail you a printed version of the Operational Instructions B.8.1 on request.

These documents are also available as **PDF download** on our website **www.mayr.com**.

ROBA-stop®-M – Guidelines



Guidelines on the Declaration of Conformity: A conformity evaluation has been carried out for the product (electromagnetic safety brake) in terms of the EU Low Voltage Directive 2014/35/EU. The Declaration of Conformity is laid out in writing in a separate document and can be requested if required.

Guidelines on the EMC Directive (2014/30/EU): The product cannot be operated independently according to the EMC directive.

Due to their passive state, brakes are also non-critical equipment according to the EMC. Only after integration of the product into an overall system can this be evaluated in terms of the EMC. For electronic equipment, the evaluation has been verified for the individual product in laboratory conditions, but not in the overall system.

Guidelines on the Machinery Directive (2006/42/EC): The product is a component for installation into machines according to the Machinery Directive 2006/42/EC. The brakes can fulfil the specifications for safety-related applications in coordination with other elements. The type and scope of the required measures result from the machine risk analysis. The brake then becomes a machine component and the machine manufacturer assesses the conformity of the safety device to the directive. It is forbidden to start use of the product until you have ensured that the machine accords with the regulations stated in the directive.

Guidelines on the ATEX Directive: Without a conformity evaluation, this product is not suitable for use in areas where there is a high danger of explosion. For application of this product in areas where there is a high danger of explosion, it must be classified and marked according to directive 2014/34/EU.

Safety Regulations

Brakes may generate several risks, among others:



During the risk assessment required when designing the machine or system, the dangers involved must be evaluated and removed by taking appropriate protective measures.

To prevent injury or damage, only professionals and specialists are allowed to work on the devices. They must be familiar with the dimensioning, transport, installation, initial operation, maintenance and disposal according to the relevant standards and regulations.

Application Conditions



The catalogue values are guideline values which have been determined in test facilities. It may be necessary to carry out your own tests for the intended application.

When dimensioning the brakes, please remember that installation situations, braking torque fluctuations, permitted friction work, run-in behaviour and wear as well as general ambient conditions can all affect the given values. These factors should therefore be carefully assessed, and alignments made accordingly.

- Mounting dimensions and connection dimensions must be adjusted according to the size of the brake at the place of installation.
- The magnetic coils are designed for a relative duty cycle of 100%, if no other values are stated.
- The braking torque is dependent on the present run-in condition of the brake.
- The brakes are only designed for dry running. The torque is lost if the friction surfaces come into contact with oil, grease, water or similar substances or foreign bodies.
- Manufacturer-side corrosion protection of the metallic surfaces.
- The rotors may rust up and seize up in corrosive ambient conditions and/or after long periods of storage.

Ambient Temperature: -20 °C up to +40 °C

Protection

IP54: When installed, dust-proof and protected against contact as well as against water spray from any direction (dependent on customer-side mounting method).

IP66 (Type 891..._4.1): Dust-proof and protected against contact as well as against strong jet water from a nozzle coming from any direction.

Grounding Connection

The brake is designed for Protection Class I. This protection covers not only the basic insulation, but also the connection of all conductive parts to the protective conductor (PE) on the fixed installation. If the basic insulation fails, no contact voltage will remain. Please carry out a standardised inspection of the protective conductor connections to all contactable metal parts!

Intended Use

mayr®-brakes have been developed, manufactured and tested in compliance with the VDE 0580 standard and in accordance with the EU Low Voltage Directive as electromagnetic components. During installation, operation and maintenance of the product, the standard requirements must be observed. mayr®-brakes are for use in machines and systems and must only be used in the situations for which they are ordered and confirmed. Using them for any other purpose is not allowed.

Guidelines for Electromagnetic Compatibility (EMC)

In accordance with the EMC directives 2014/30/EU, the individual components produce no emissions. However, functional components e.g. mains-side energisation of the brakes with rectifiers, phase demodulators, ROBA®-switch devices or similar controls can produce disturbance which lies above the allowed limit values.

For this reason it is important to read the Installation and Operational Instructions very carefully and to keep to the EMC directives.

Standards, Directives and Regulations Used

VDE 0580	Electromagnetic devices and components, general specifications
2014/35/EU	Low Voltage Directive
CSA C22.2 No. 14-2010	Industrial Control Equipment
UL 508 (Edition 17)	Industrial Control Equipment
EN ISO 12100	Safety of machinery - General principles for design - Risk assessment and risk reduction
EN 61000-6-4	Interference emission
EN 61000-6-2	Interference immunity
EN 60204-1	Electrical equipment of machines

Liability

- The information, guidelines and technical data in these documents were up to date at the time of printing. Demands on previously delivered brakes are not valid.
- Liability for damage and operational malfunctions will not be taken if: the Installation and Operational Instructions are ignored or neglected, the brakes are used inappropriately, the brakes are modified, the brakes are worked on unprofessionally and the brakes are handled or operated incorrectly.

Guarantee

- The guarantee conditions correspond with the Chr. Mayr GmbH + Co. KG sales and delivery conditions.
- Mistakes or deficiencies are to be reported to mayr® at once.

Notes

Product Summary

Torque Limiters/Overload Clutches

- ❑ **EAS®-Compact®/EAS®-NC/EAS®-smartic®**
Positive locking and completely backlash-free torque limiting clutches
- ❑ **EAS®-reverse**
Reversing re-engaging torque limiting clutch
- ❑ **EAS®-element clutch/EAS®-elements**
Load-disconnecting protection against high torques
- ❑ **EAS®-axial**
Exact limitation of tensile and compressive forces
- ❑ **EAS®-Sp/EAS®-Sm/EAS®-Zr**
Load-disconnecting torque limiting clutches with switching function
- ❑ **ROBA®-slip hubs**
Load-holding, frictionally locked torque limiting clutches
- ❑ **ROBA®-contitorque**
Magnetic continuous slip clutches
- ❑ **EAS®-HSC/EAS®-HSE**
High-speed torque limiters for high-speed applications



Shaft Couplings

- ❑ **smartflex®/primeflex®**
Perfect precision couplings for servo and stepping motors
- ❑ **ROBA®-ES**
Backlash-free and damping for vibration-sensitive drives
- ❑ **ROBA®-DS/ROBA®-D**
Backlash-free, torsionally rigid all-steel couplings
- ❑ **ROBA®-DSM**
Cost-effective torque-measuring couplings

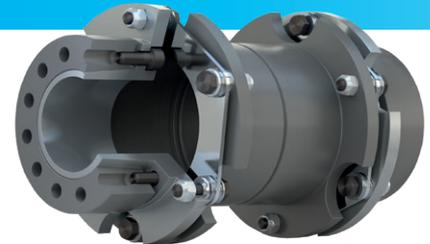

Electromagnetic Brakes/Clutches

- ❑ **ROBA-stop® standard**
Multifunctional all-round safety brakes
- ❑ **ROBA-stop®-M motor brakes**
Robust, cost-effective motor brakes
- ❑ **ROBA-stop®-S**
Water-proof, robust monoblock brakes
- ❑ **ROBA®-duplostop®/ROBA®-twinstop®/ROBA-stop®-silenzio®**
Doubly safe elevator brakes
- ❑ **ROBA®-diskstop®**
Compact, very quiet disk brakes
- ❑ **ROBA®-topstop®**
Brake systems for gravity loaded axes
- ❑ **ROBA®-linearstop**
Backlash-free brake systems for linear motor axes
- ❑ **ROBA®-guidestop**
Backlash-free holding brake for profiled rail guides
- ❑ **ROBATIC®/ROBA®-quick/ROBA®-takt**
Electromagnetic clutches and brakes, clutch brake units

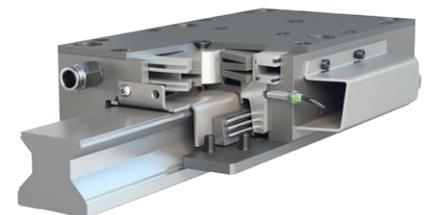
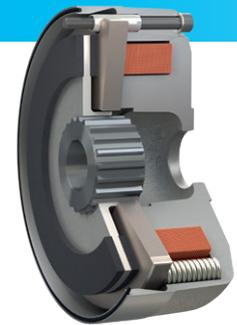

DC Drives

- ❑ **tendo®-PM**
Permanent magnet-excited DC motors

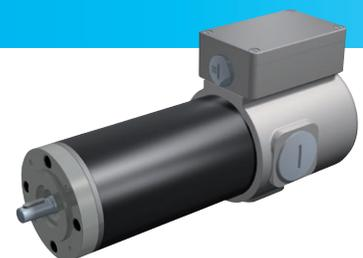

Headquarters

Chr. Mayr GmbH + Co. KG
Eichenstraße 1, D-87665 Mauerstetten
Tel.: +49 83 41/8 04-0, Fax: +49 83 41/80 44 21
www.mayr.com, E-Mail: public.mayr@mayr.com



Service Germany/Austria

Baden-Württemberg

Esslinger Straße 7
70771 Leinfelden-Echterdingen
Tel.: 07 11/78 26 26 40
Fax: 07 11/78 26 26 39

Bavaria

Industriestraße 51
82194 Gröbenzell
Tel.: 0 81 42/50 19 808

Chemnitz

Bornaer Straße 205
09114 Chemnitz
Tel.: 03 71/4 74 18 96
Fax: 03 71/4 74 18 95

Franken

Unterer Markt 9
91217 Hersbruck
Tel.: 0 91 51/81 48 64
Fax: 0 91 51/81 62 45

Kamen

Herbert-Wehner-Straße 2
59174 Kamen
Tel.: 0 23 07/24 26 79
Fax: 0 23 07/24 26 74

North

Schiefer Brink 8
32699 Extertal
Tel.: 0 57 54/9 20 77
Fax: 0 57 54/9 20 78

Rhine-Main

Kohlhäuser Str. 3-5
36043 Fulda
Tel.: 06 61/96 21 02 15

Austria

Pummerinplatz 1, TIZ I, A27
4490 St. Florian, Austria
Tel.: 0 72 24/2 20 81-12
Fax: 0 72 24/2 20 81 89

Branch office

China

Mayr Zhangjiagang
Power Transmission Co., Ltd.
Fuxin Road No.1298, Yangshe Town
215637 Zhangjiagang
Tel.: 05 12/58 91-75 67
Fax: 05 12/58 91-75 66
info@mayr-ptc.cn

France

Mayr France S.A.S.
Z.A.L. du Minopole
Rue Nungesser et Coli
62160 Bully-Les-Mines
Tel.: 03.21.72.91.91
Fax: 03.21.29.71.77
contact@mayr.fr

Great Britain

Mayr Transmissions Ltd.
Valley Road, Business Park
Keighley, BD21 4LZ
West Yorkshire
Tel.: 0 15 35/66 39 00
Fax: 0 15 35/66 32 61
sales@mayr.co.uk

Italy

Mayr Italia S.r.l.
Viale Veneto, 3
35020 Saonara (PD)
Tel.: 049/879 10 20
Fax: 049/879 10 22
info@mayr-italia.it

Japan

Mayr Japan LLC
Higano Nihonbashi Building 2F,
1-1-9 Nihonbashi Kakigara-cho,
Chuo-ku Tokyo, 103-0014 Japan
Tel.: 03/35 27-29 00
Fax: 03/35 27-26 61
public.mayr@mayr.co.jp

Singapore

Mayr Transmission (S) PTE Ltd.
No. 8 Boon Lay Way Unit 03-06,
TradeHub 21
Singapore 609964
Tel.: 00 65/65 60 12 30
Fax: 00 65/65 60 10 00
info@mayr.com.sg

Switzerland

Mayr Kupplungen AG
Tobeläckerstraße 11
8212 Neuhausen am Rheinfall
Tel.: 0 52/6 74 08 70
Fax: 0 52/6 74 08 75
info@mayr.ch

USA

Mayr Corporation
10 Industrial Avenue
Mahwah
NJ 07430
Tel.: 2 01/4 45-72 10
Fax: 2 01/4 45-80 19
info@mayrcorp.com

Representatives

Australia

Drive Systems Pty Ltd.
8/32 Melverton Drive
Hallam, Victoria 3803
Australien
Tel.: 0 3/97 96 48 00
info@drivesystems.com.au

India

National Engineering
Company (NENCO)
J-225, M.I.D.C.
Bhosari Pune 411026
Tel.: 0 20/27 13 00 29
Fax: 0 20/27 13 02 29
nenco@nenco.org

Netherlands

Groneman BV
Amarilstraat 11
7554 TV Hengelo OV
Tel.: 074/2 55 11 40
Fax: 074/2 55 11 09
aandrijftechnik@groneman.nl

Poland

Wamex Sp. z o.o.
ul. Pozaryskiego, 28
04-703 Warszawa
Tel.: 0 22/6 15 90 80
Fax: 0 22/8 15 61 80
wamex@wamex.com.pl

South Korea

Mayr Korea Co. Ltd.
15, Yeondeok-ro 9beon-gil
Seongsan-gu
51571 Changwon-si
Gyeongsangnam-do. Korea
Tel.: 0 55/2 62-40 24
Fax: 0 55/2 62-40 25
info@mayrkorea.com

Taiwan

German Tech
Component Co., Ltd.
No.10-3, Ln. 358, Sec. 1,
Hemu Rd., Shengang Dist.,
429012 Taichung City
Tel.: +886 (4) 25150566
Fax: +886 (4) 25152413
abby@zfgta.com.tw

Czech Republic

BMC - TECH s.r.o.
Hviezdoslavova 29 b
62700 Brno
Tel.: 05/45 22 60 47
Fax: 05/45 22 60 48
info@bmc-tech.cz

Turkey

Representative Office Turkey
Kucukbakkalkoy Mah.
Brandium Residence R2
Blok D:254
34750 Atasehir - Istanbul, Turkey
Tel.: 02 16/2 32 20 44
Fax: 02 16/5 04 41 72
info@mayr.com.tr

More representatives:

Belgium, Brazil, Canada, Colombia, Croatia, Denmark, Finland, Greece, Hongkong, Hungary, Indonesia, Israel, Luxembourg, Malaysia, Mexico, New Zealand, Norway, Philippines, Portugal, Romania, Russia, Slovakia, Slovenia, South Africa, Spain, Sweden, Thailand

You can find the complete contact details for the representative responsible for your area in the Contact section at www.mayr.com

